

**SPIRALIS**

# THREE LINKAGE SLIDING DOOR SYSTEM

## TECHNICAL DATA SHEET

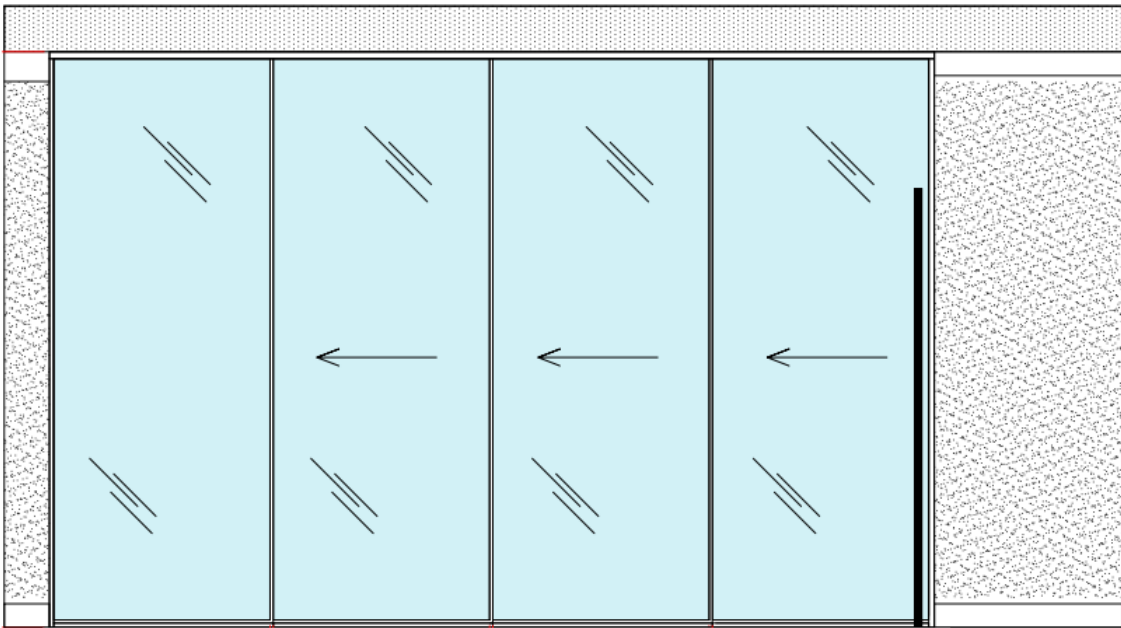

# THREE LINKAGE SLIDING DOOR SYSTEM

## TECHNICAL DATA SHEET

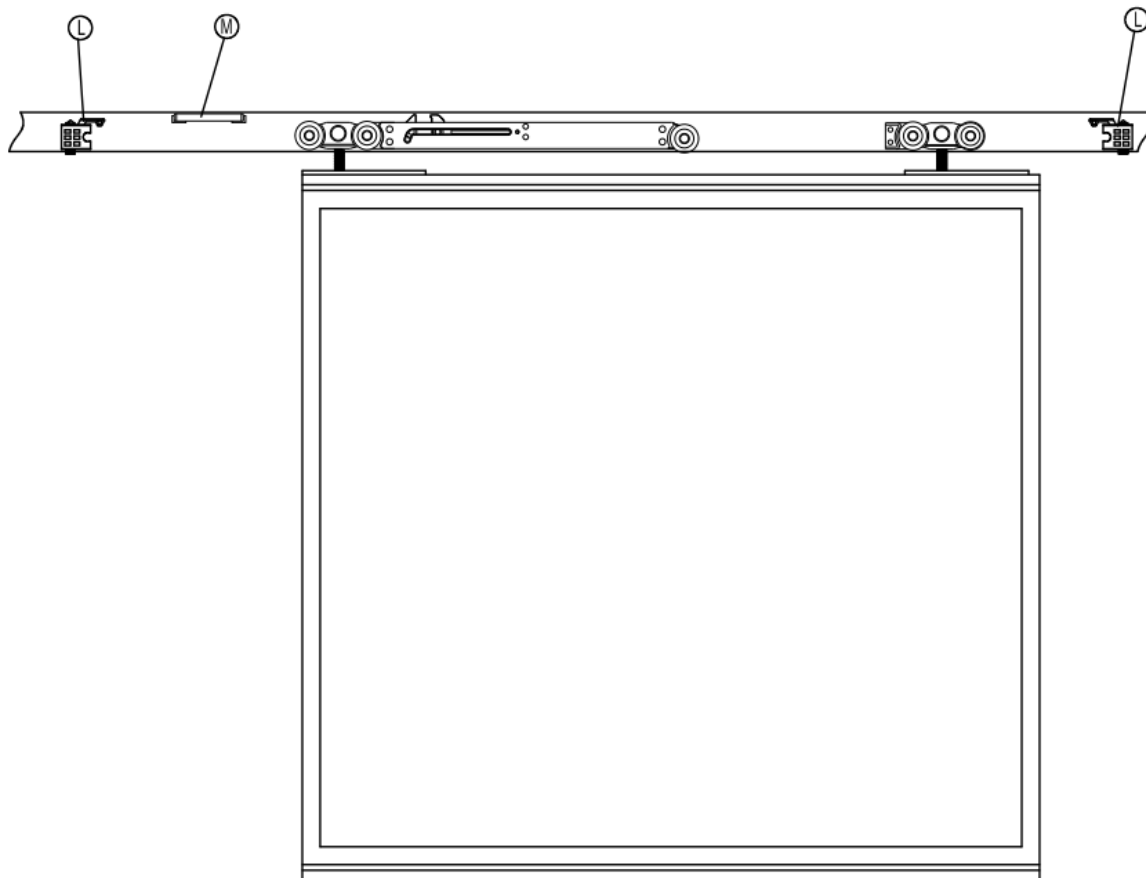

### INFORMATION:









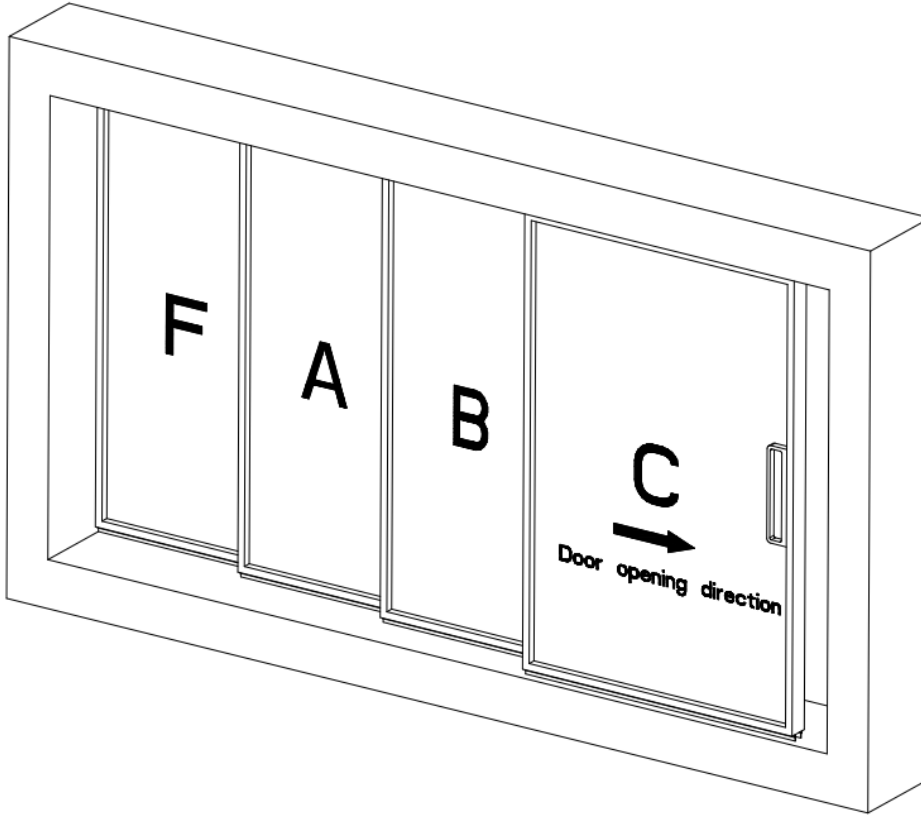



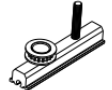

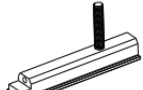
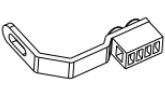
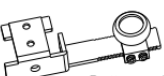
- Model: 3L Sliding system
- Synchronized three linkage sliding door system
- Application: commercial interior glass doors
- Door quantity: 1 fixed and 3 mobile doors
- Door sizes: variable
- Door weight: variable
- Glass thickness: 11.5mm
- Track length: up to 4500mm
- Finish: black matt powder coating
- Left opening or right opening.

# THREE LINKAGE SLIDING DOOR SYSTEM

## TECHNICAL DATA SHEET

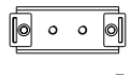
COMPONENTS:

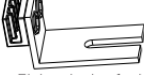

 <p>A</p>	 <p>B</p>	 <p>C</p>	 <p>D</p>	 <p>E</p>	 <p>F</p>
 <p>G</p>	 <p>H</p>	 <p>I</p>	 <p>J</p>	 <p>K</p>	
 <p>L</p>	 <p>M</p>	 <p>N</p>	 <p>O</p>	 <p>P</p>	

# THREE LINKAGE SLIDING DOOR SYSTEM

## TECHNICAL DATA SHEET

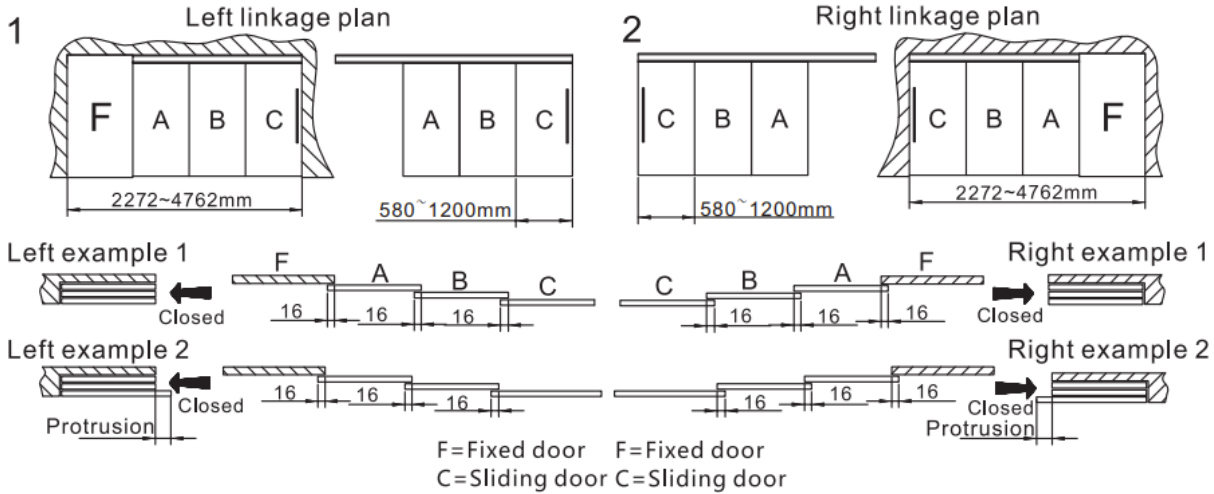

**3** Cross section diagram of Left linkage

**4** Cross section diagram of Right linkage

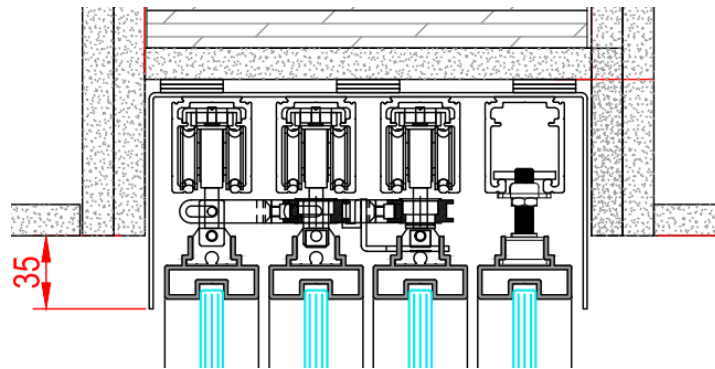
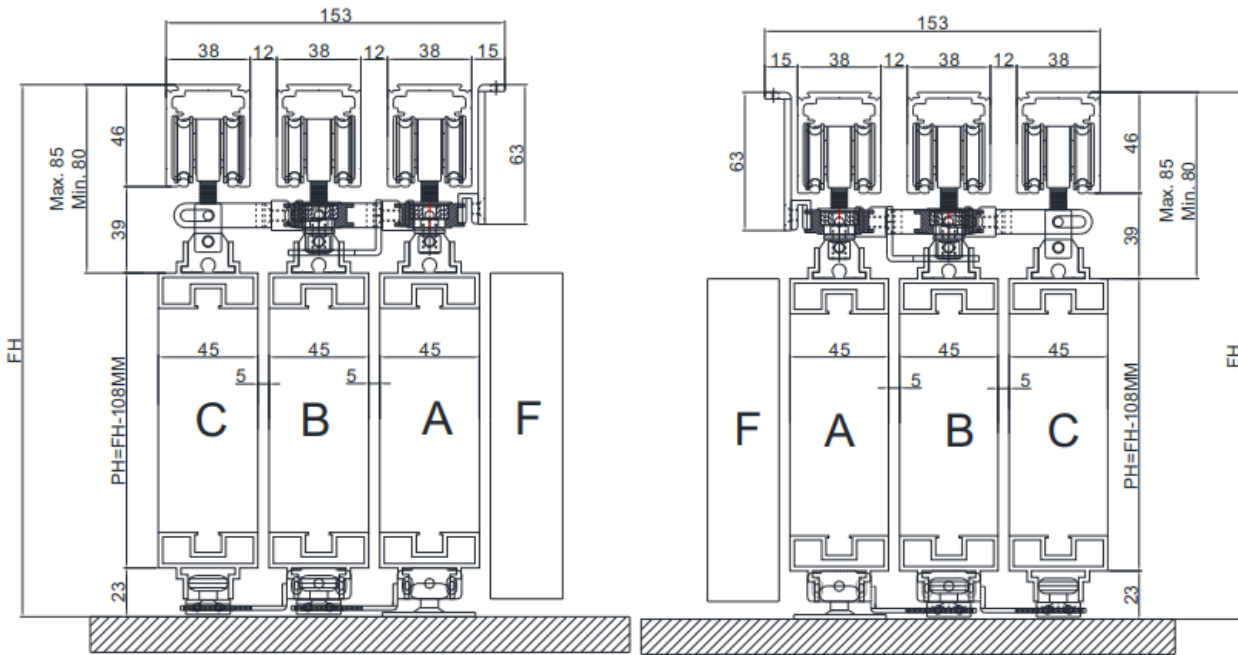

# THREE LINKAGE SLIDING DOOR SYSTEM

## TECHNICAL DATA SHEET

### 5 Calculation formula of door width:

-----The calculation formulas of left example 1 and right example 1 are the same

(Left example 1)

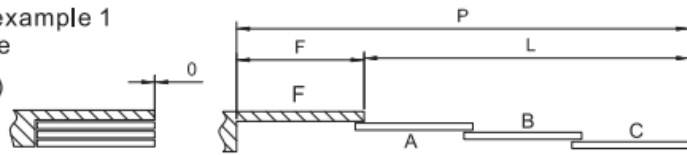

$$L = \frac{3(P-26)}{4}$$

$$C = (L/3) + 16$$

$$B = (L/3) + 16$$

$$A = (L/3) + 16$$

$$F = (L/3) + 26$$

$$P = L + F$$

Door height=Door frame height-98

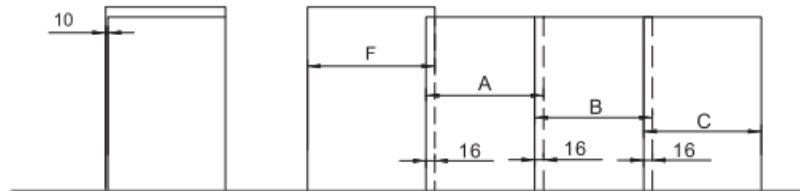

(Right example 1)

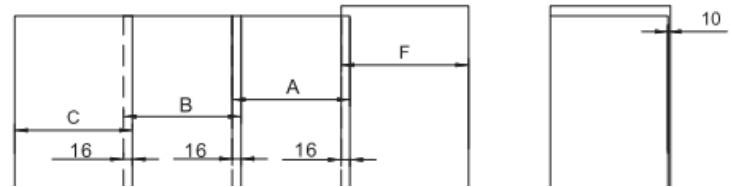
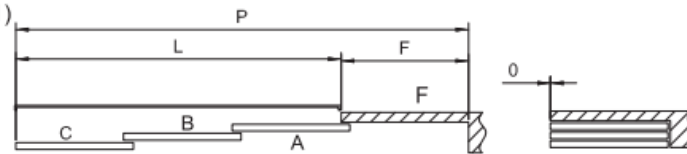

### 6 Calculation formula of door width:

-----The calculation formulas of left example 2 and right example 2 are the same

(Left example 2)

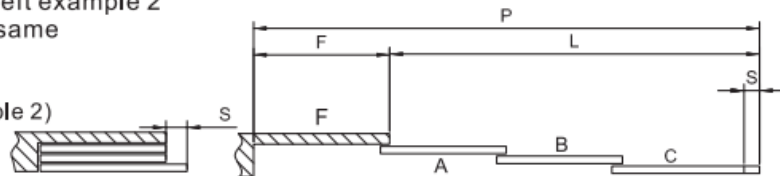

$$L = \frac{3(P-26)+S}{4}$$

$$A = \frac{L-S}{3} + 16$$

$$B = \frac{L-S}{3} + 16$$

$$C = \frac{L+2S}{3} + 16$$

$$F = \frac{L-S}{3} + 26$$

$$P = L + F$$

Door height=Door frame height-98

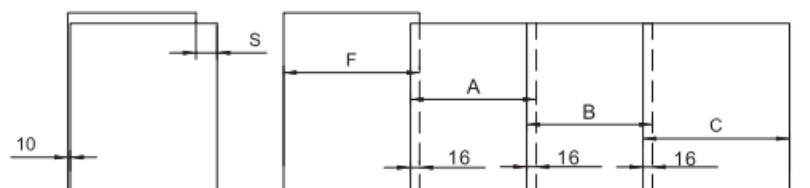

(Right example 2)

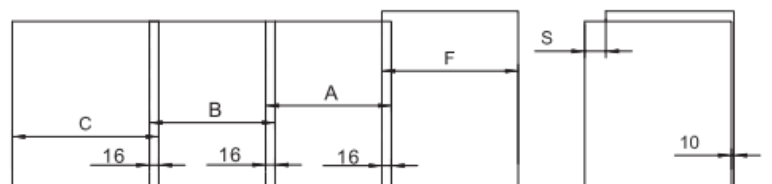
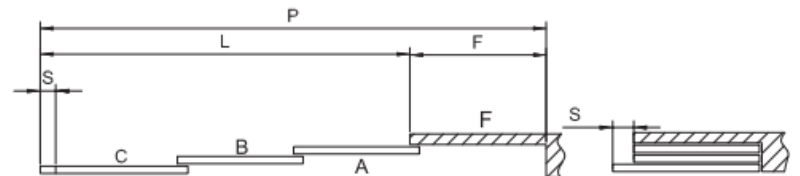

# THREE LINKAGE SLIDING DOOR SYSTEM

## TECHNICAL DATA SHEET

### 5-1 Example of door size calculation:

-----The calculation formulas of left example 1 and right example 1 are the same

(Left example 1)

$$L = \frac{(Px3)-165}{4} \quad P=3200\text{mm}$$

$$L = \frac{3(3200-26)}{4} = 2380.5\text{mm}$$

$$C = (L/3) + 16$$

$$B = (L/3) + 16$$

$$A = (L/3) + 16$$

$$F = (L/3) + 26$$

$$P = L + F$$

$$C = (2380.5/3) + 16 = 809.5\text{mm}$$

$$B = (2380.5/3) + 16 = 809.5\text{mm}$$

$$A = (2380.5/3) + 16 = 809.5\text{mm}$$

$$F = (2380.5/3) + 26 = 819.5\text{mm}$$

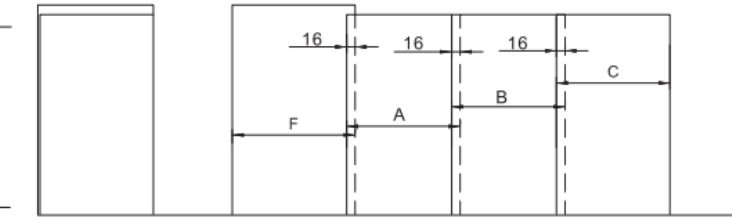
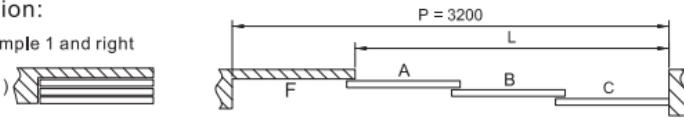

(Right example 1)

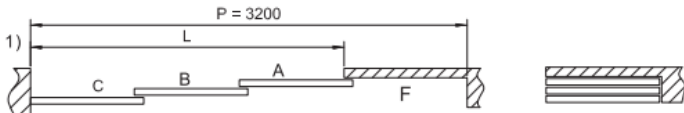

Door frame height=2400mm  
Door height=Door frame height-98  
Door height=2400-98=2302mm

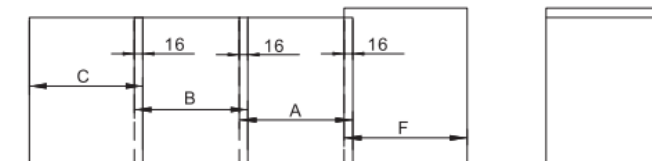

### 6-1 Example of door size calculation:

-----The calculation formulas of left example 2 and right example 2 are the same

(Left example 2)

$$L = \frac{3(P-26)+S}{4} \quad P=3200\text{mm} \quad S=80\text{mm}$$

$$L = \frac{3(3200-26)+80}{4} = 2400.5\text{mm}$$

$$A = \frac{L-S}{3} + 16$$

$$B = \frac{L-S}{3} + 16$$

$$C = \frac{L+2S}{3} + 16$$

$$F = \frac{L-S}{3} + 26$$

$$P = L + F$$

$$A = \frac{2400.5-80}{3} + 16 = 789.5\text{mm}$$

$$B = \frac{2400.5-80}{3} + 16 = 789.5\text{mm}$$

$$C = \frac{2400.5+2 \times 80}{3} + 16 = 869.5\text{mm}$$

$$A = \frac{2400.5-80}{3} + 26 = 799.5\text{mm}$$

(Right example 2)

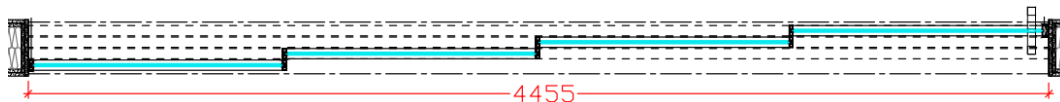
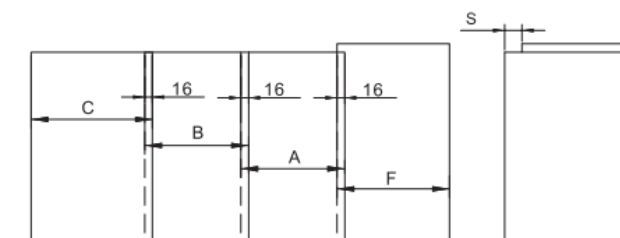
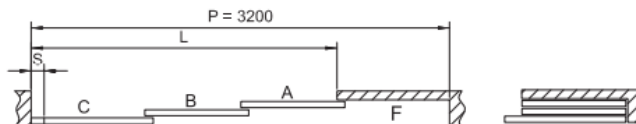
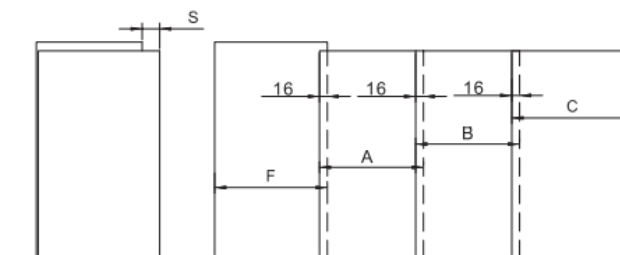
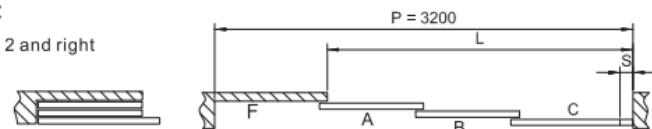

# THREE LINKAGE SLIDING DOOR SYSTEM

## TECHNICAL DATA SHEET

### 7 Installation components

#### 7-1 Right linkage

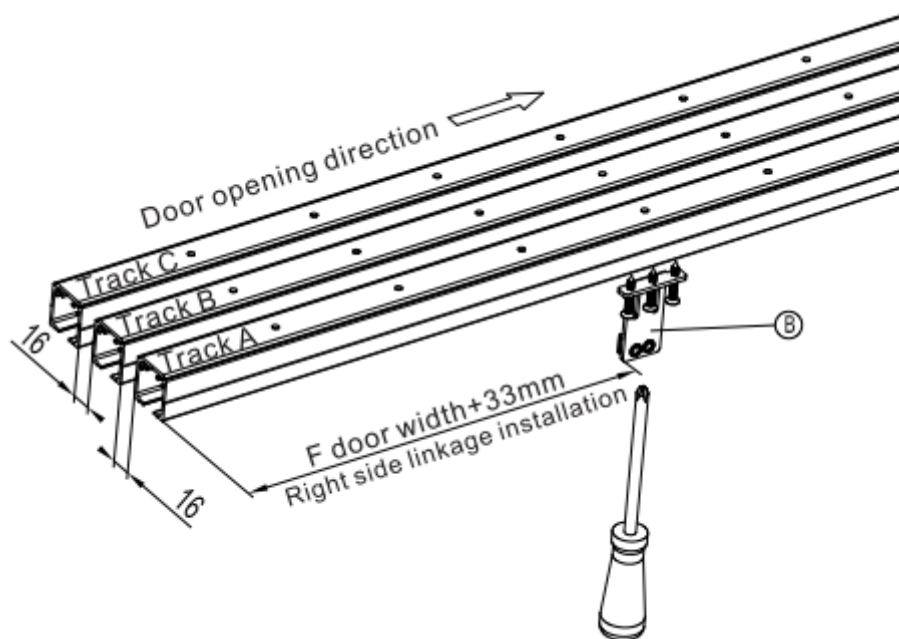
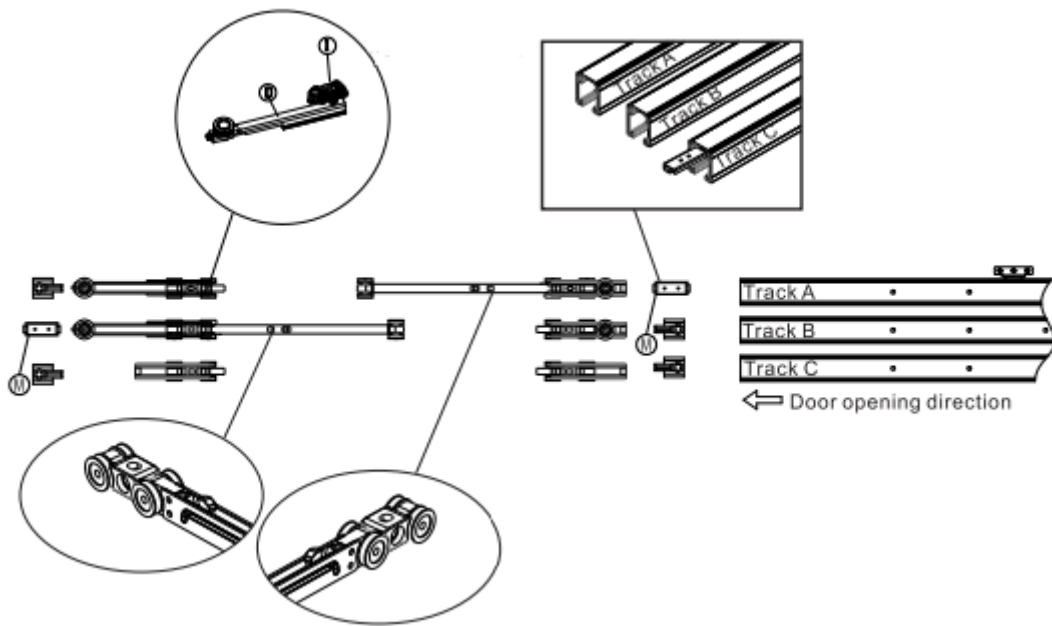
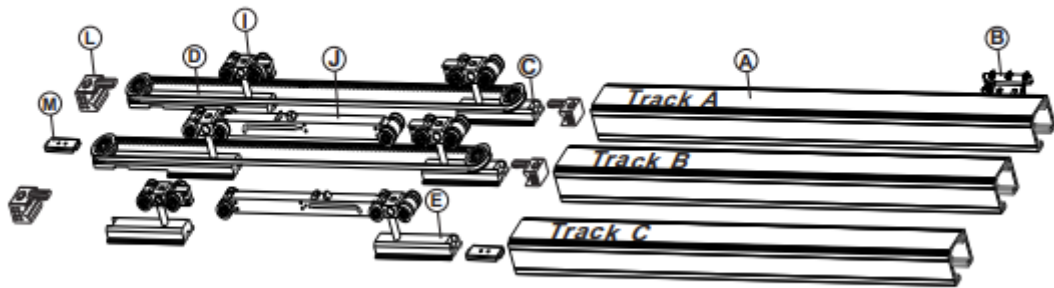

# THREE LINKAGE SLIDING DOOR SYSTEM

## TECHNICAL DATA SHEET

### 7-2 Left linkage

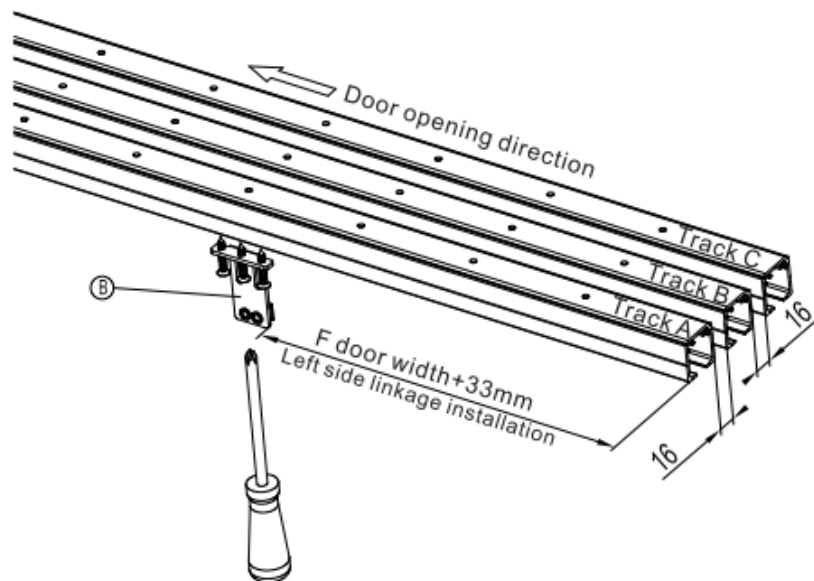
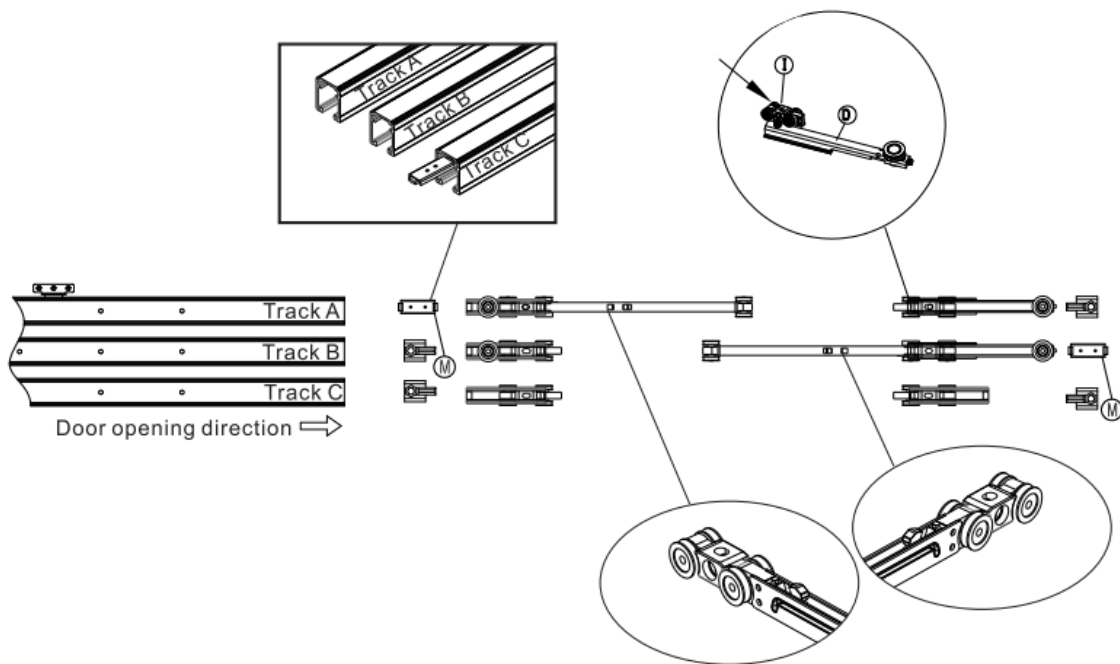
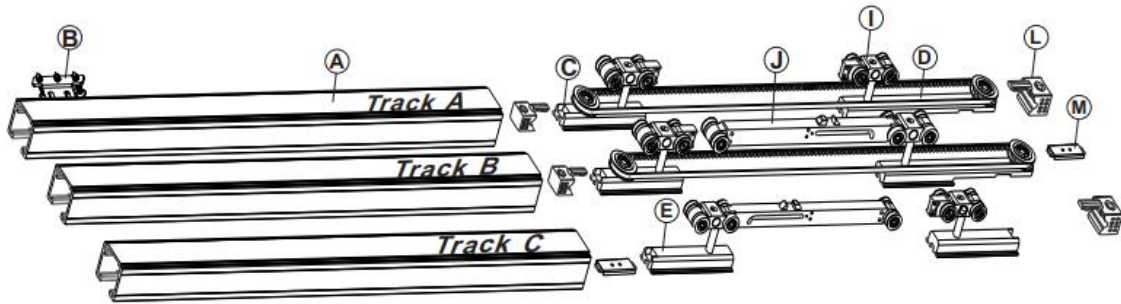



# THREE LINKAGE SLIDING DOOR SYSTEM

## TECHNICAL DATA SHEET

### 8 Install hanger locating piece

#### 8-1 Right linkage

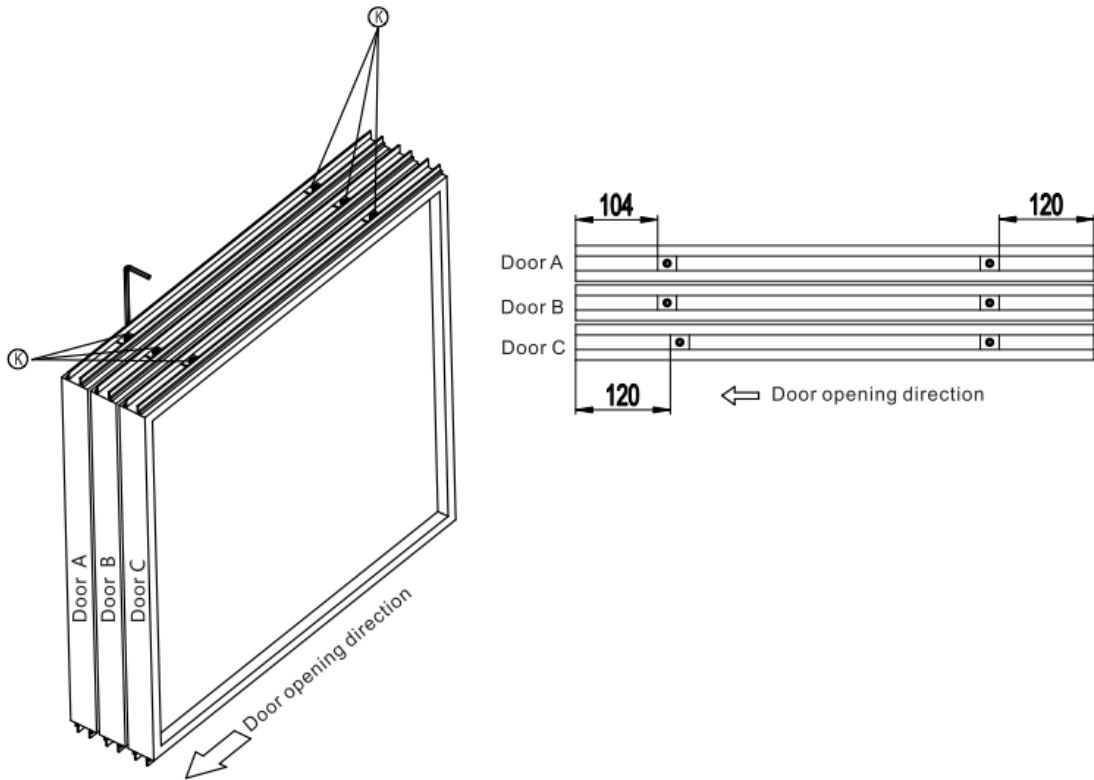

#### 8-2 Left linkage

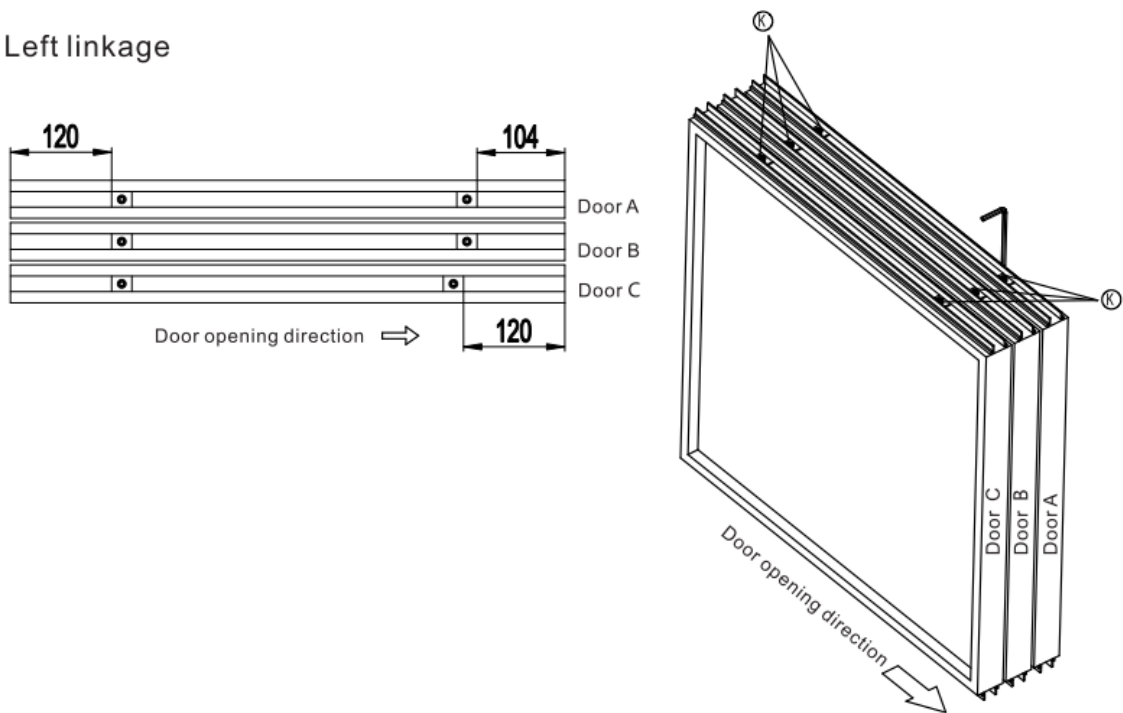

# THREE LINKAGE SLIDING DOOR SYSTEM

## TECHNICAL DATA SHEET

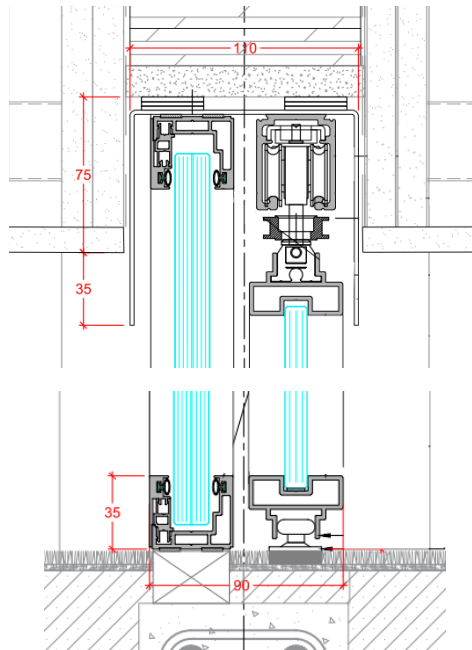
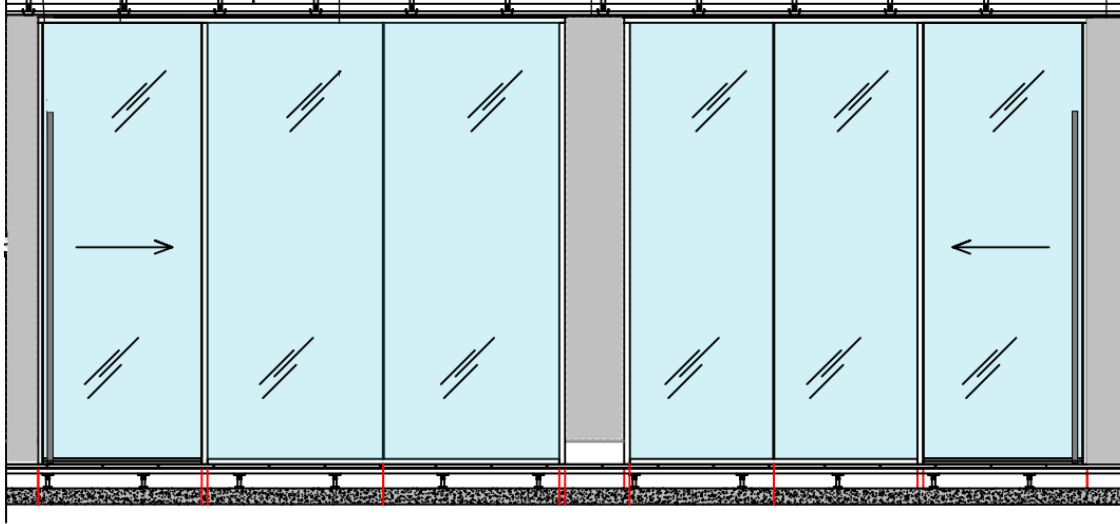

DP7 - SINGLE SLIDING DOOR PARTITION  
SCALE 1:5